

Owners Manual

TABLE BILLIARD

Model#SUB-7240

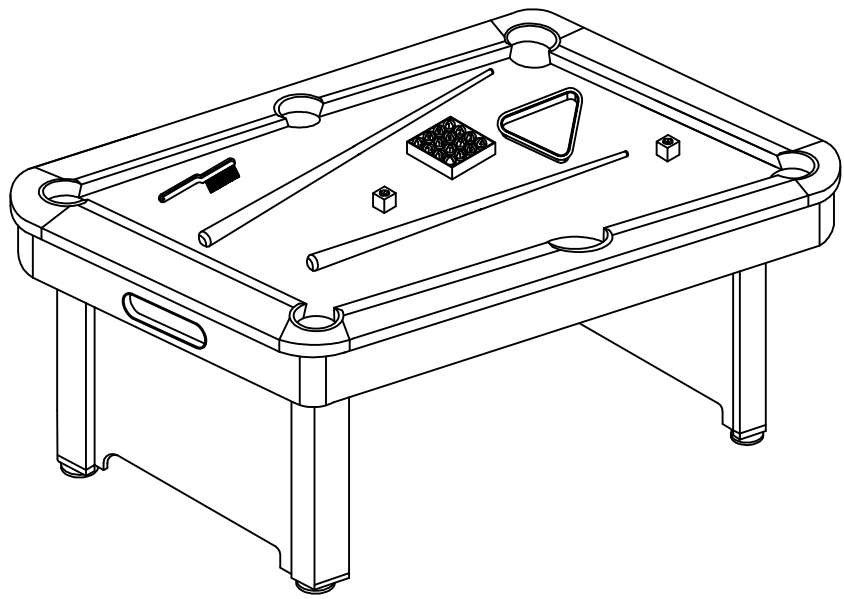

.Assembly Instructions

.Parts List











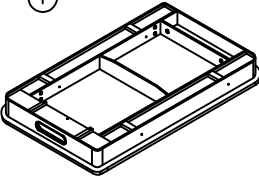

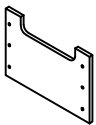

WARNING: Choking Hazard--Toy contains small balls and/or small parts. Not for children under 3 years.

IMPORTANT!

Please Keep Your Instructions. Before attempting assembly, please read through this instruction book to familiarize yourself with all the parts and assembly steps. Please refer to the Parts List below and be sure that all parts have been included.

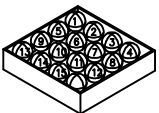
PARTS LIST

<p>①</p>  <p>CABINET FOR BILLIARD 1EA</p>	<p>②</p>  <p>LEFT LEG 2EA</p>	<p>③</p>  <p>RIGHT LEG 2EA</p>	<p>④</p>  <p>END LEG BRACE 2EA</p>	<p>⑤</p>  <p>8X30MM LEG BOLT 12EA</p>
<p>⑥</p>  <p>20X8.5MM WASHER 12EA</p>	<p>⑦</p>  <p>3.5X14MM WASHER HEAD SCREW 12EA</p>	<p>⑧</p>  <p>LEG LEVELER 4EA</p>	<p>⑨</p>  <p>ALLEN WRENCH 1EA</p>	<p>⑩</p>  <p>CHALK 2EA</p>
<p>⑪</p>  <p>CUE STICK 2EA</p>	<p>⑫</p>  <p>TRIANGLE 1EA</p>	<p>⑬</p>  <p>BILLIARD BALLS 1EA</p>	<p>⑭</p>  <p>BRUSH 1EA</p>	

ASSEMBLY INSTRUCTIONS:

We recommend that two adults work together to assemble this game.

Step 1 - Open the carton of your new billiard game near where your game will be played. Select a clear level floor. The table will be assembled upside down and then turned over onto its legs. Use the bottom carton to assemble the game and protect the game. Carefully cut or tear the carton corners so that bottom carton becomes a flat working surface area.

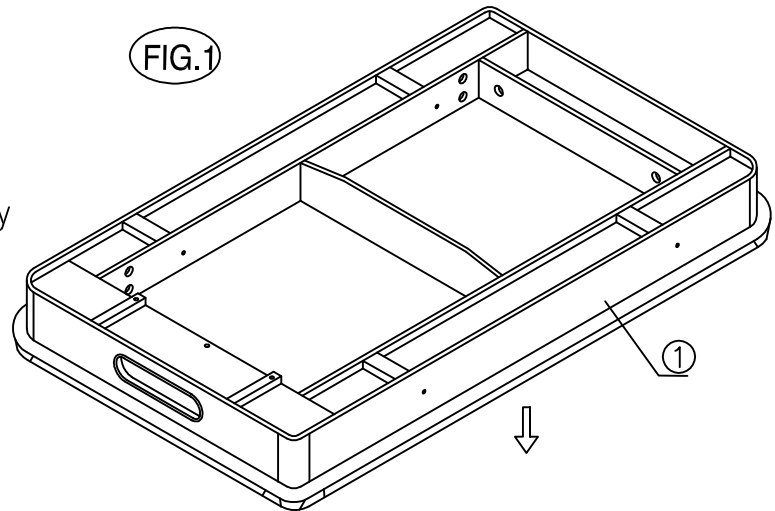

Step 2 - Attach Left (#2) and Right (#3) Legs to the support frame using three of the Leg Bolts (#5) and three of the Washers (#6) per leg. Then locate the four Leg Levelers (#8) and screw one into each Leg. See FIG.2.

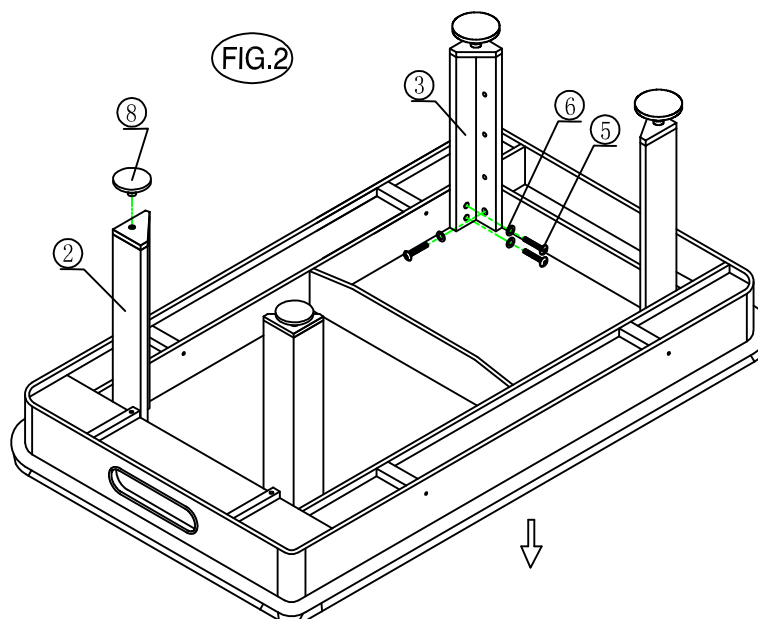

Step 3 - Attach two End Leg Braces (#4) to Legs using three of Washer Head Screws (#7) per leg. See FIG.3.

Step 4 - Now tighten all Leg and Leg Brace Bolts.

Step 5 - Lift the table assembly from the floor with two strong adults, turn it over, and set table on its legs in the location where you

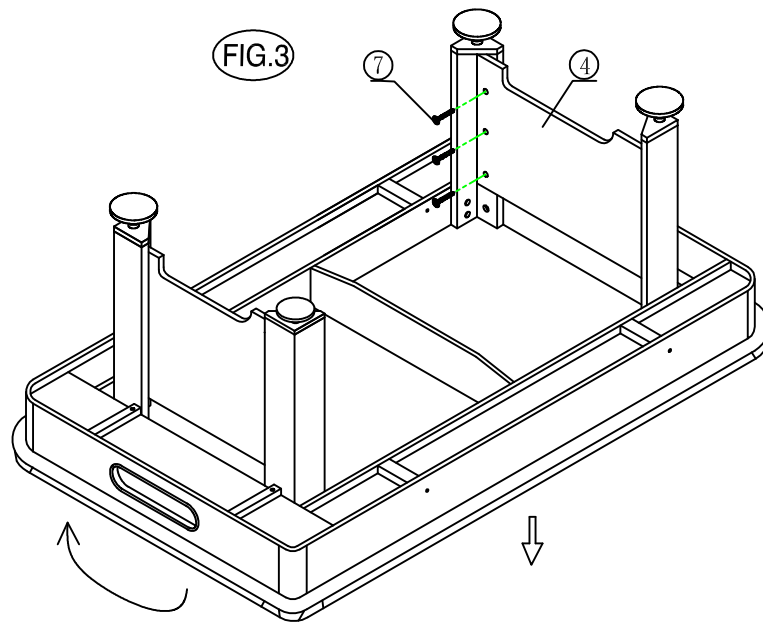

CAUTION: Two adults are recommended to flip the table as shown.
1. Grab the table on the ground.
2. Turn the table over.
3. Place it on all four feet at the same time on the ground.

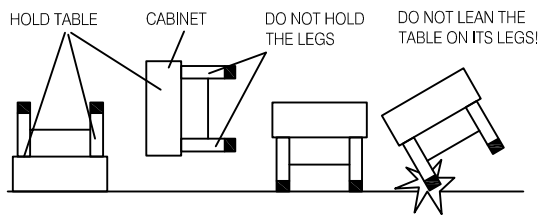

Step 6 - Place a carpenter's level in various positions on the playing surface to determine where leveling adjustments may be needed and adjust the leg levelers as needed to ensure that the table is level.

YOU ARE NOW READY TO PLAY

